

DYSTRYBUTOR



**TECHNICAL**

**GRZEGORZ TĘGOS**

TECHNIKA NAPIĘDU I TRANSMISJI MOCY

62-600 Koło, ul. Toruńska 212  
tel. 0-63/ 27 25 478 / fax. 0-63/ 26 16 258

[www.technical.pl](http://www.technical.pl)  
[biuro@technical.pl](mailto:biuro@technical.pl)

Sklep internetowy  
[www.sklep.technical.pl](http://www.sklep.technical.pl)

# **Elektrobębny i bębny zwrotne**

**LAT**  
ANTRIEBSTECHNIK

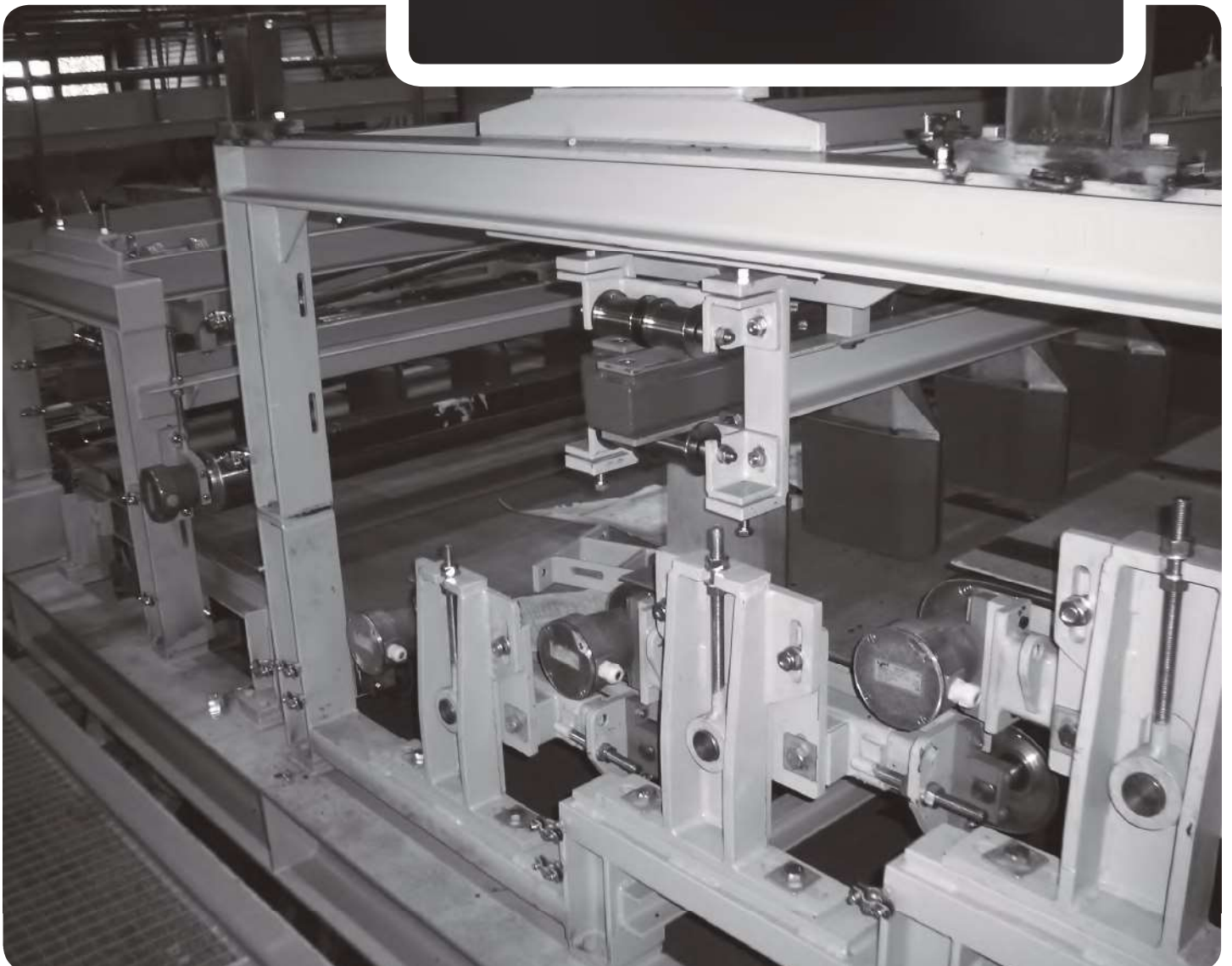

## Trommelmotor / Drum Motor Typ TM 113 Standard

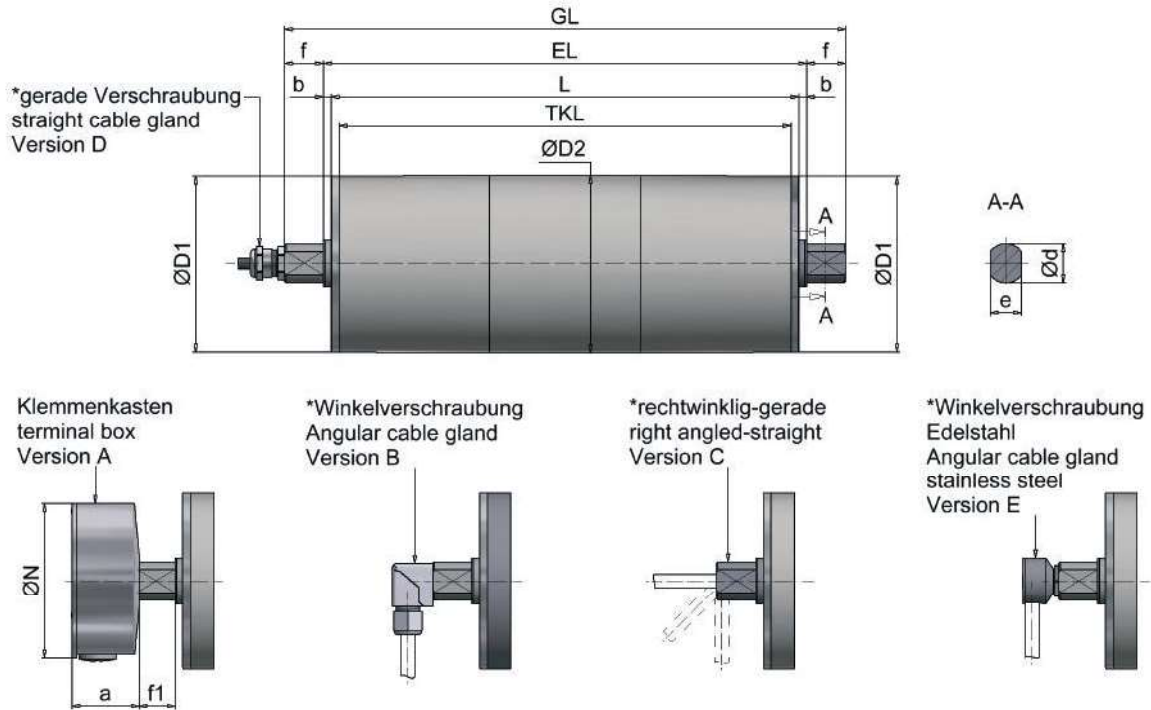

## Umlenktrummel / Guide Drum Motor Typ UT 113 Standard

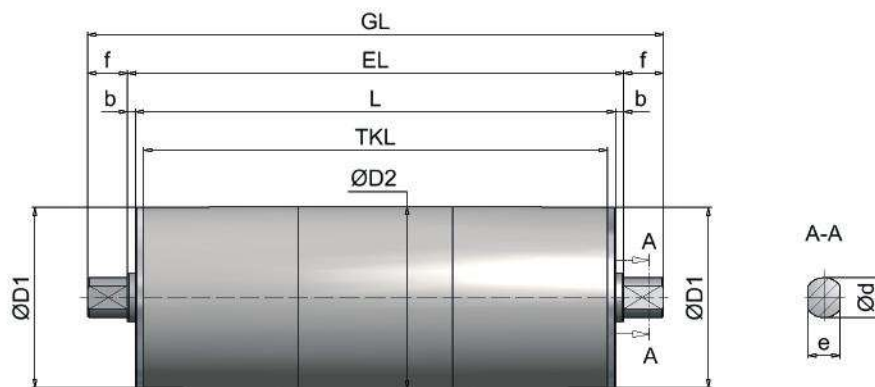

alle Maße in mm / dimensions in mm

TROMMELMOTOR / DRUM MOTOR											STANDARD IP66	
Größe / size	Typ	ØD1**	ØD2**	a	ØN	Ød	e	f	f1	TKL	b	EL
113	TM 113.1	112,5	113,5	43	100	25	20	25	23	L - 10	5	L + 10
UMLENKTROMMEL / GUIDE DRUM												
113	TM 113.1	112,5	113,5			25	20	25		L - 10	5	L + 10

\* mit 3m Kabel / with 3m cable

\*\* Durchmesser bei zylindrischem Trommelkörper 113 / diameter with cylindrical drum design 113



## Leistungsdaten / Performance data Typ TM113

TYP	LEISTUNG / POWER	GESCHWINDIG- KEIT / BELT SPEED	DREHZAHL / ROTATION SPEED	BANDZUG- KRAFT / BELT PULL	TROMMEL- MOMENT / TORQUE	STROMAUF- NAHME BEI / POWER INPUT AT 400V / 50Hz	TROMMEL- LÄNGE / DRUM LENGTH L min.	GEWICHT / WEIGHT
	P2	v	n2	F	T2			L=400mm
	[kW]	[m/s]	[1/min]	[N]	[Nm]	[A]	[mm]	[kg]
TM113.1	0,075 8-polig	0,09	16	795	45	0,45	260	12,5
		0,12	19	650	37			
		0,14	23	541	31			
		0,16	28	456	26			
		0,19	33	388	22			
		0,23	38	333	19			
		0,26	44	286	16			
		0,28	47	271	15			
		0,34	57	221	13			
		0,41	68	184	10			
		0,48	81	155	9			
		0,57	95	132	8			
		0,66	111	113	6			
0,77	129	98	6					
TM113.1	0,12 6-polig	0,14	23	876	50	0,57	260	12,5
		0,17	28	716	41			
		0,20	34	596	34			
		0,24	40	503	29			
		0,28	47	428	24			
		0,33	55	367	21			
		0,38	64	316	18			
		0,40	68	299	17			
		0,49	83	244	14			
		0,59	99	203	12			
		0,70	118	171	10			
		0,82	138	146	8			
		0,96	162	125	7			
1,11	188	108	6					
TM113.1	0,18 4-polig	0,21	36	845	48	0,68	260	12,5
		0,26	44	690	39			
		0,31	53	575	33			
		0,37	63	485	27			
		0,44	73	413	23			
		0,51	86	354	20			
		0,59	99	304	17			
		0,63	105	288	16			
		0,76	129	235	13			
		0,92	155	196	11			
		1,09	183	165	9			
		1,28	215	141	8			
		1,49	251	121	7			
1,73	292	104	6					

## Leistungsdaten / Performance data Typ TM113

TYP	LEISTUNG / POWER	GESCHWINDIG- KEIT / BELT SPEED	DREHZAHL / ROTATION SPEED	BANDZUG- KRAFT / BELT PULL	TROMMEL- MOMENT / TORQUE	STROMAUF- NAHME BEI / POWER INPUT AT 400V / 50Hz	TROMMEL- LÄNGE / DRUM LENGTH L min.	GEWICHT / WEIGHT
	P2	v	n2	F	T2			L=400mm
	[kW]	[m/s]	[1/min]	[N]	[Nm]	[A]	[mm]	[kg]
TM113.1	0,25 4-polig	0,21	36	1173	67	0,94	260	12,5
		0,26	44	959	54			
		0,31	53	798	45			
		0,37	63	673	38			
		0,44	73	573	33			
		0,51	86	491	28			
		0,59	99	423	24			
		0,63	105	400	23			
		0,76	129	327	19			
		0,92	155	272	15			
		1,09	183	229	13			
		1,28	215	195	11			
		1,49	251	167	10			
1,73	292	144	8					
TM113.1	0,30 4-polig	0,21	36	1408	80	1,10	280	13,6
		0,26	44	1151	65			
		0,31	53	958	54			
		0,37	63	808	46			
		0,44	73	688	39			
		0,51	86	589	33			
		0,59	99	507	29			
		0,63	105	480	27			
		0,76	129	392	22			
		0,92	155	326	19			
		1,09	183	275	16			
		1,28	215	234	13			
		1,49	251	201	11			
1,73	292	173	10					
TM113.1	0,37 2-polig	0,43	72	868	49	0,95	260	12,5
		0,52	88	710	40			
		0,63	105	591	34			
		0,74	125	498	28			
		0,87	147	424	24			
		1,02	171	363	21			
		1,18	199	313	18			
		1,25	210	296	17			
		1,53	257	242	14			
		1,84	309	201	11			
		2,18	367	170	10			
		2,56	431	145	8			
		2,99	503	124	7			
3,47	584	107	6					



## Leistungsdaten / Performance data Typ TM113

TYP	LEISTUNG / POWER	GESCHWINDIG- KEIT / BELT SPEED	DREHZAHL / ROTATION SPEED	BANDZUG- KRAFT / BELT PULL	TROMMEL- MOMENT / TORQUE	STROMAUF- NAHME BEI / POWER INPUT AT 400V / 50Hz	TROMMEL- LÄNGE / DRUM LENGTH L min.	GEWICHT / WEIGHT
	P2	v	n2	F	T2			L=400mm
	[kW]	[m/s]	[1/min]	[N]	[Nm]	[A]	[mm]	[kg]
TM113.1	0,55 2-polig	0,42	71	1300	74	1,26	280	13,6
		0,52	87	1062	60			
		0,62	105	884	50			
		0,74	124	746	42			
		0,87	146	635	36			
		1,01	170	544	31			
		1,17	198	469	27			
		1,24	209	443	25			
		1,52	256	362	21			
		1,82	307	301	17			
		2,16	364	254	14			
		2,54	428	216	12			
		2,97	499	185	11			
		3,44	579	160	9			

- abweichende Leistungsdaten und Geschwindigkeiten auf Anfrage
- Gewichtsangabe inkl. Ölfüllung (betriebsbereit)
- Mehrgewicht: ca. 1kg auf 100mm Mehrlänge
- bei Bremsanbau erhöht sich das L min. Maß um 65mm

- alternative performance data and speeds on request
- indication of weight incl. oil filling (ready for operating)
- additional weight: approx. 1kg for 100mm add. length
- with brake mounting L min. dimension raises up 65mm

**Normbreiten [L] : 260, 280, 310, 360 ... 810mm**  
ab 810mm verstärkte Ausführung.

**norm width [L] : 260, 280, 310, 360 ... 810mm,**  
from 810mm reinforced construction

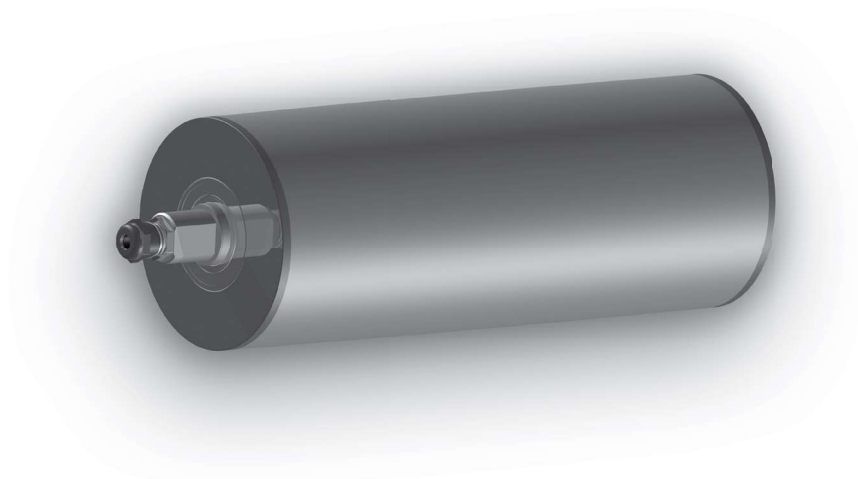

## Ausführungsarten und Optionen / Design types and options

### STANDARDAUSFÜHRUNG

- ballig gedrehter Stahlmantel, stahlblank, mit Rostschutz überzogen
- Lagerenddeckel aus Aluminium
- Einspannzapfen aus Stahl, mit Rostschutz überzogen
- Stirnradgetriebe in Stahlverzahnung (geräuscharm)
- Gerade Verschraubung (inkl. 3m Kabel)

### STANDARD CONFIGURATION

- *crowned shell, mild steel with rust protection paint*
- *bearing covers made of aluminium*
- *shafts made of mild steel with rust protection paint*
- *helical gear unit with steel toothing (quiet)*
- *straight cable gland (with 3m cable)*

### OPTIONEN

- innenliegende Bremse
- mit Klemmenkasten
- Winkelverschraubung (mit 3m Kabel)
- Winkelverschraubung Edelstahl (mit 3m Kabel)
- Rechtwinklig-gerade Verschraubung (mit 3m Kabel)
- Rücklaufsperr (Kugellagerfreilauf)
- Kettenrad / Zahnriemenscheibe
- Sensorlagereinheit (Drehgeber)
- Trommelkörper zylindrisch, gummiert, verzinkt (kundenspezifisch)
- Edelstahlausführung
- Thermokontakte
- IP67
- geeignet für Frequenzrichterbetrieb
- für Kunststoffmodularbänder und Profulgummierungen
- Klemmenkastenausführung in Edelstahl
- vertikaler Einbau möglich (bei Bestellung angeben)
- Lebensmittelöl
- Trommelmotor als Einbaupatrone
- Einphasen-Wechselstrom Motoren auf Anfrage

Weitere Ausführungen nach Kundenwunsch möglich.

### OPTIONS

- *internal brake*
- *with terminal box*
- *angular cable gland (with 3m cable)*
- *angular cable gland stainless steel (with 3m cable)*
- *right angled-straight cable gland (with 3m cable)*
- *backstop*
- *sprocket / toothed belt disc*
- *sensor bearing unit (rotary encoder)*
- *cylindrical drum shell, coated, zinc plated (customised)*
- *stainless steel design*
- *thermal contact*
- *IP67*
- *suitable for frequency converter use*
- *for modular plastic conveyor belts and grooved rubber lagging*
- *terminal box design in stainless steel*
- *vertical mounting (should be stated in the order)*
- *food-safe lubricant*
- *Drum Motor as cartridge*
- *single phase motors on request*

Other designs on customer request possible.

## Einspannlager für HIMMEL® Trommelmotor / Umlenktrommel Typ 113 Clamping bearing for HIMMEL® Drum Motor / Guide Drum type 113

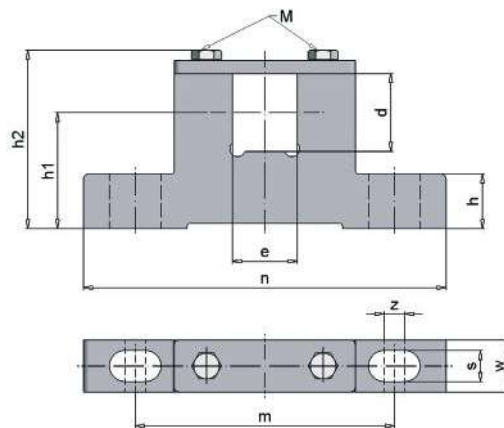

alle Maße in mm / dimensions in mm

TROMMELTYP / DRUM TYPE	EINSPANNLAGER / CLAMPING BEARING	d	e	h	h1	h2	m	n	s	w	z	M	MATERIAL / MATERIAL	ca. kg
TM113.1	EL25/20	25	20	21	44,5	66	100	140	12	20	8	M6	Stahl / Steel	0,7

