

DYSTRYBUTOR



**TECHNICAL**

**GRZEGORZ TĘGOS**

TECHNIKA NAPĘDU I TRANSMISJI MOCY

62-600 Koło, ul. Toruńska 212  
tel. 0-63/ 27 25 478 / fax. 0-63/ 26 16 258

[www.technical.pl](http://www.technical.pl)  
[biuro@technical.pl](mailto:biuro@technical.pl)

Sklep internetowy  
[www.sklep.technical.pl](http://www.sklep.technical.pl)

**Przekładnie pasowe  
bezstopniowe  
wariatorowe**



*Infinitely variable, mechanical  
speed adjustment control:*

**BERGES**

*Assembly units RGAE.*

## BERGES Assembly Units RGAE

In this modular system, the proven BERGES double pulley drive with a wide V-belt is integrated in a symmetrical housing. The numerous possibilities offered by this design range from modular assembly of a wide variety of drive elements up to a connection-ready, compact variable gear unit.

Spindle and angle adjustment controls with disc-type or scale handwheel as well as hydraulic and electrical remote controls are available for speed adjustment. Incl. speed indicators (analogous or digital) and tachometers.

Three-phase motors as well as reduction gears of all types with connections in accordance with IEC can be mounted directly both in U and in Z configurations.

On the output side, every BERGES assembly unit can be equipped as standard with a two-bearing input or output shaft in flange design. This in turn allows connection of output elements in conjunction with chain or belt drives. At the same time, this shaft design provides the input for reduction gears with IEC connection (hollow shaft). A gear pedestal is also available for every size.

The housings of RGAE sizes 2 to 9 have IEC connections on both the motor and output sides as standard. Size 1 corresponds to a works standard.



### Naturally flexible:

The variety of mounting possibilities and the clear system principle put the choice in your hands:

- You assemble and complete the BERGES assembly units yourself in accordance with our assembly instructions
- You can provide us with motors and reduction gears and we will assemble the assembly unit
- We can supply you with exactly the complete, functional drive and adjustment control unit that you need. Ready for integration in your machines and installations.



BERGES ... everything under control.

3

# Basic components with possibilities of systematic extension.

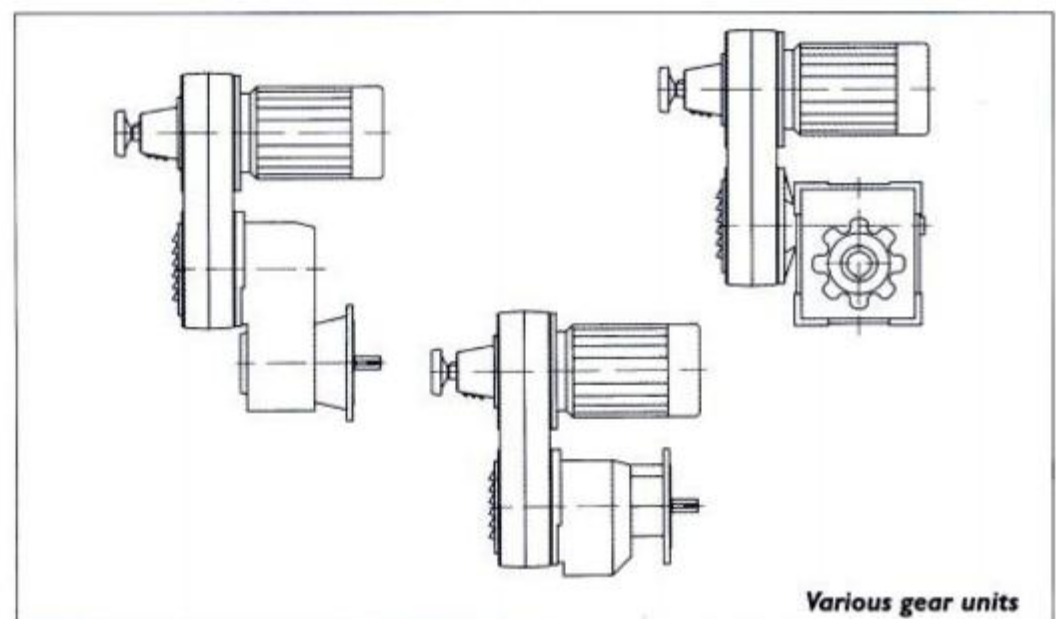
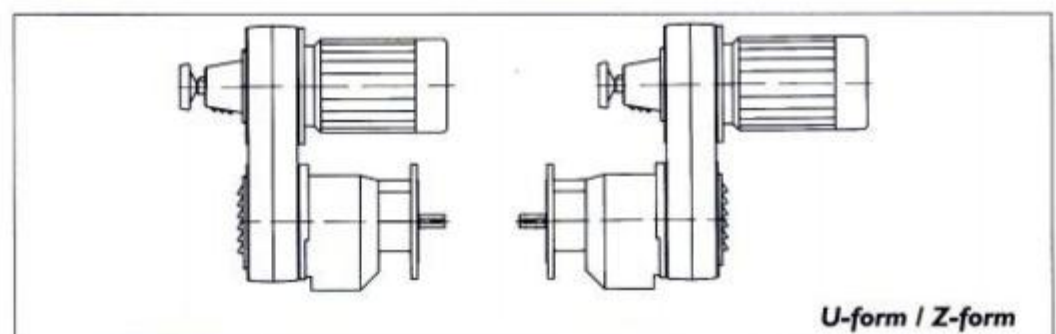
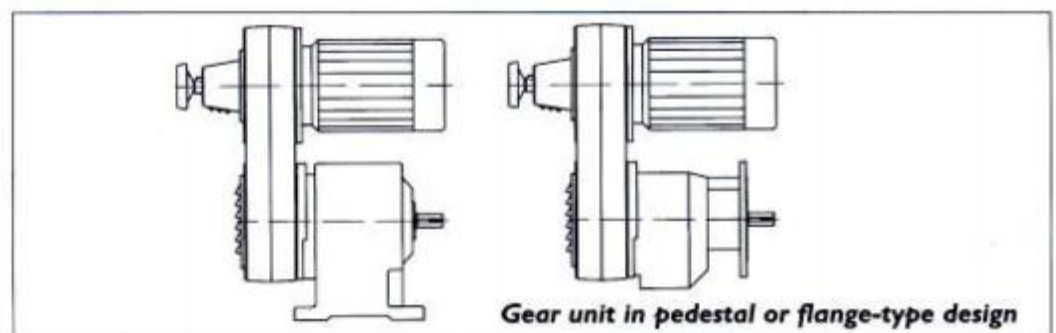
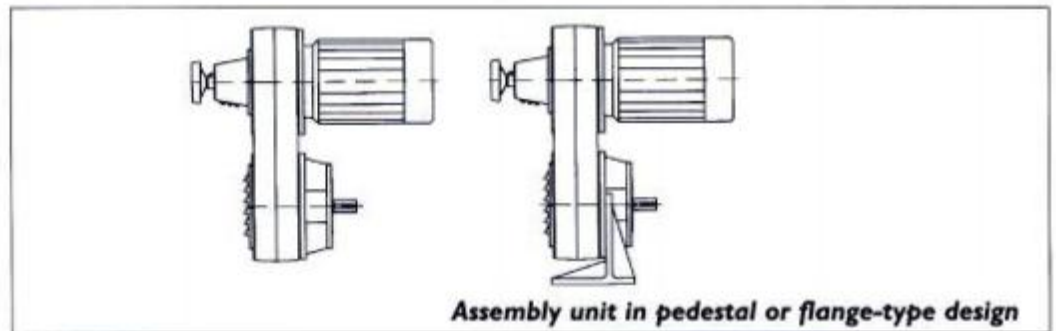

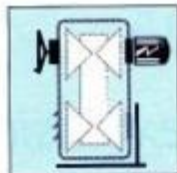
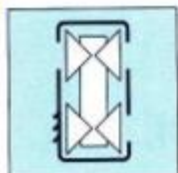

## Assembly units

# RGAE 1

$$P_{1 \max.} = 0,37 \text{ kW}$$

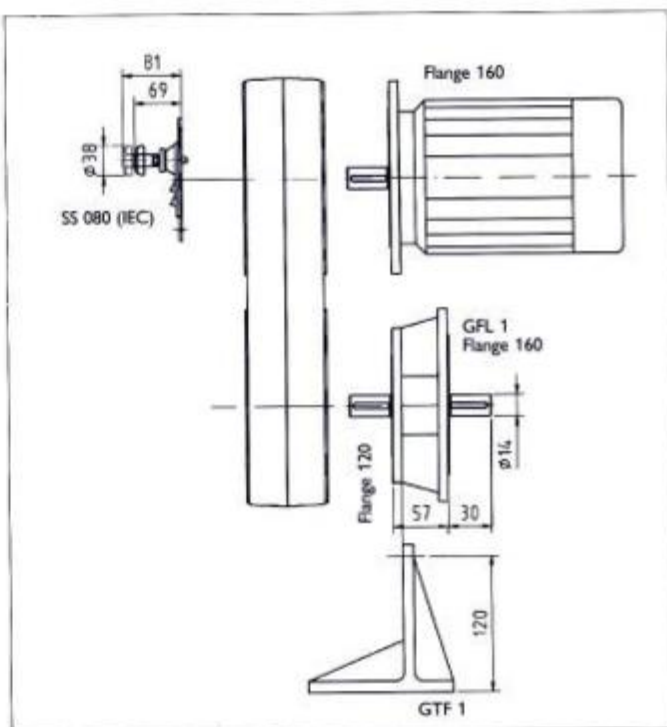
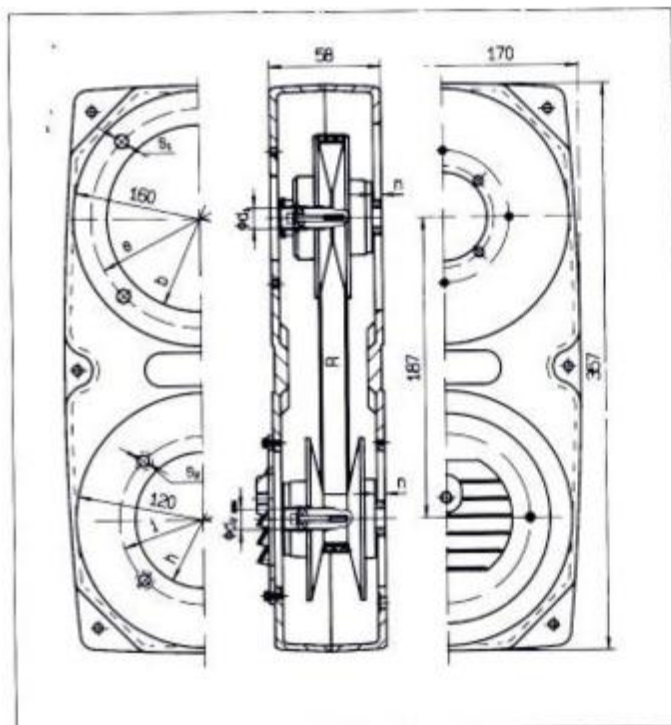

## RGAE 1

Motor size Type	Power [kW]	Nominal speed [rpm]	RGAE Type	Output power (max./min.) [kW]	Output speed (max./min.) [rpm]	Belt [Lw]	Speed range	Weight [N]
71 B5	0,37	1370	RGAE 1-080	0,33/0,17	3210/585	17 x 6 x 578	1:5,5	27

## Assembly dimensions in mm

RGAE type	d <sub>1</sub>	e	b	s <sub>1</sub>	d <sub>2max.</sub>	l	h	s <sub>2</sub>	n
RGAE 1-080	14	130	113	9	14	100	81	6,5	4



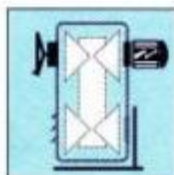
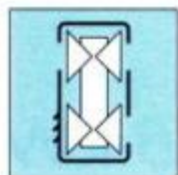

Assembly units

**RGAE 2**

$P_{1 \max.} = 1,5 \text{ kW}$

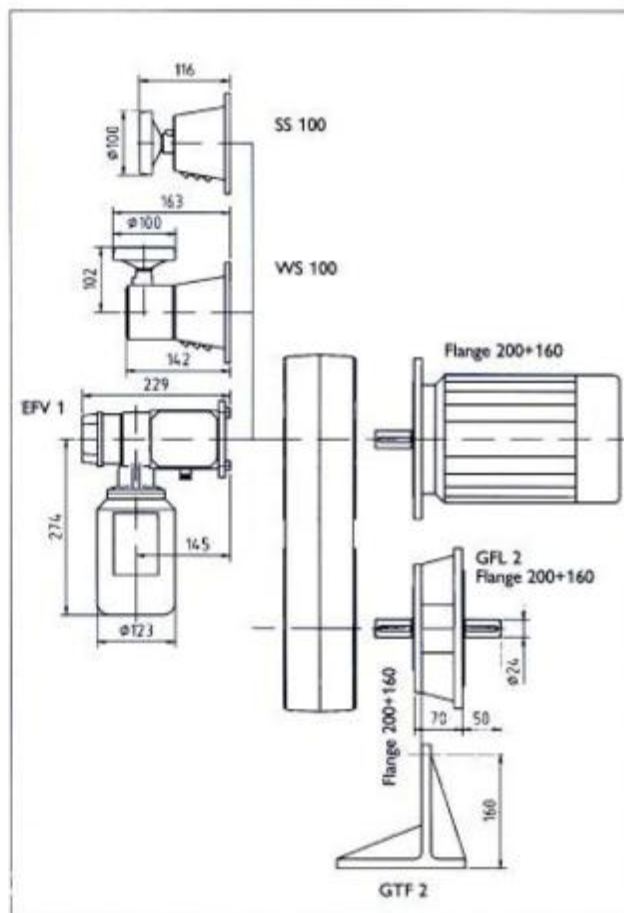
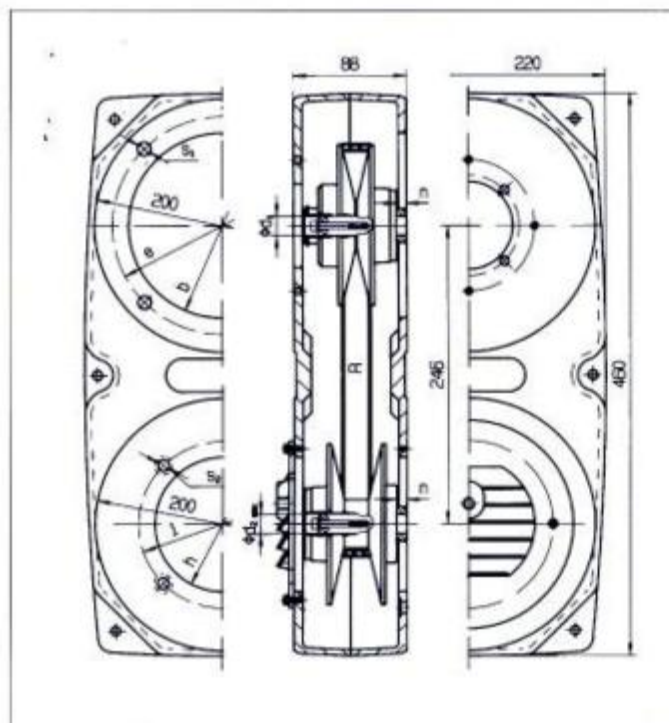

## RGAE 2

Motor size Type	Power [kW]	Nominal speed [rpm]	RGAE Type	Output power (max./min.) [kW]	Output speed (max./min.) [rpm]	Belt [Lw]	Speed range	Weight [N]
90 B5	1,5	1390	RGAE 2-100	1,35/0,55	3260/595	22 x 7 x 758	1:5,5	65

## Assembly dimensions in mm

RGAE-Typ	d <sub>1</sub>	e	b	s <sub>1</sub>	d <sub>2max.</sub>	i	h	s <sub>2</sub>	n
RGAE 2-100	24	165	133	11	24	165 130	133 113	11 9	8



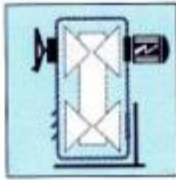
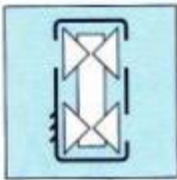

## Assembly units

# RGAE 3

$$P_{1 \max.} = 4,0 \text{ kW}$$

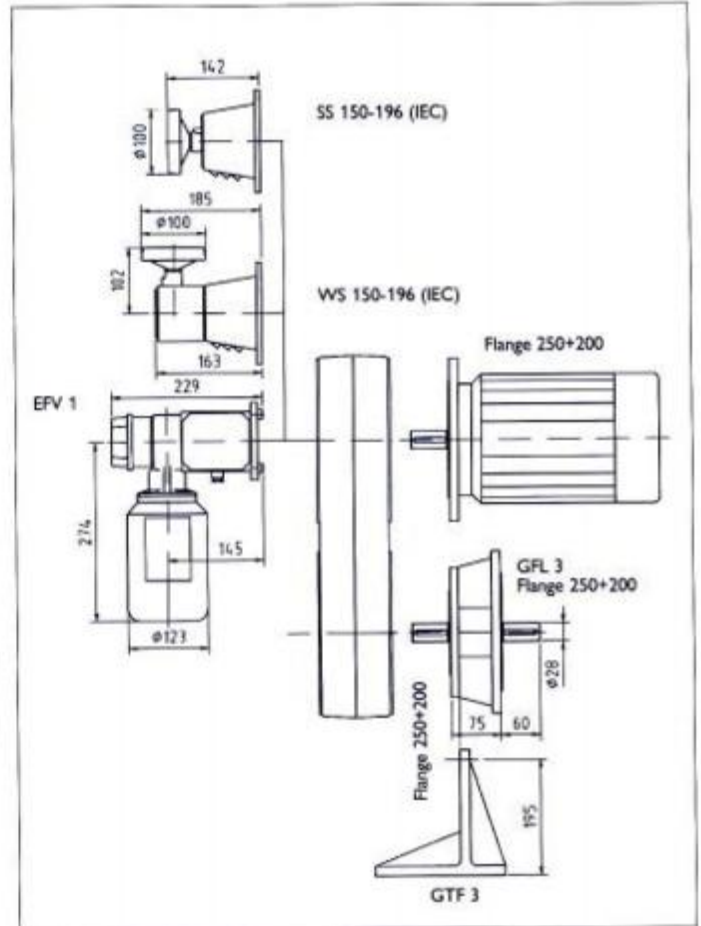
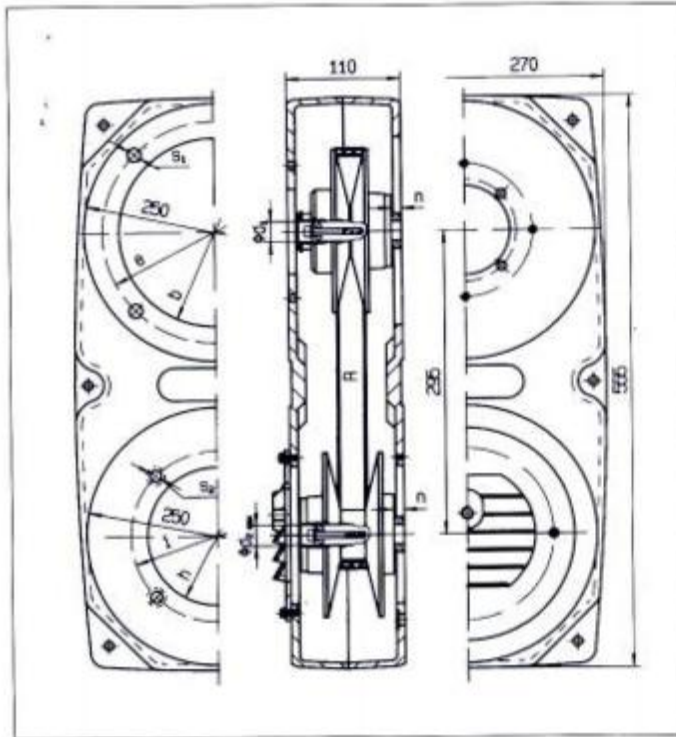

## RGAE 3

Motor size Type	Power [kW]	Nominal speed [rpm]	RGAE Type	Output power (max./min.) [kW]	Output speed (max./min.) [rpm]	Belt [Lw]	Speed range	Weight [N]
90 B5	1,5	1410	RGAE 3-190/1,5	1,35/0,75	4560/435	28 x 8 x 996	1:10,5	125
100 B5	3,0	1430	RGAE 3-150	2,7/0,9	3595/555	28 x 8 x 938	1:6,5	115
100 B5	3,0	1430	RGAE 3-190/3,0	2,7/0,85	4230/470	28 x 8 x 988	1:9,0	125
112 B5	4,0	1440	RGAE 3-196	3,6/1,2	4040/505	33 x 10 x 1020	1:8,0	140

Motors 100 B14 B and 112 B14 B can also be mounted.

## Assembly dimensions in mm

RGAE-Type	d <sub>1</sub>	e	b	s <sub>1</sub>	d <sub>2max.</sub>	i	h	s <sub>2</sub>	n
RGAE 3-190/1,5	24	165	133	11	28	215 165	183 133	13 11	10
RGAE 3-150 RGAE 3-190/3,0	28	215	183	13	28	215 165	183 133	13 11	10
RGAE 3-196	28	215	183	13	28	215 165	183 133	13 11	—



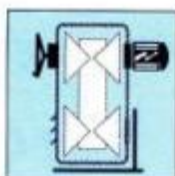
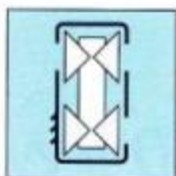

Assembly units

**RGAE 4**

$P_{1 \max.} = 7,5 \text{ kW}$

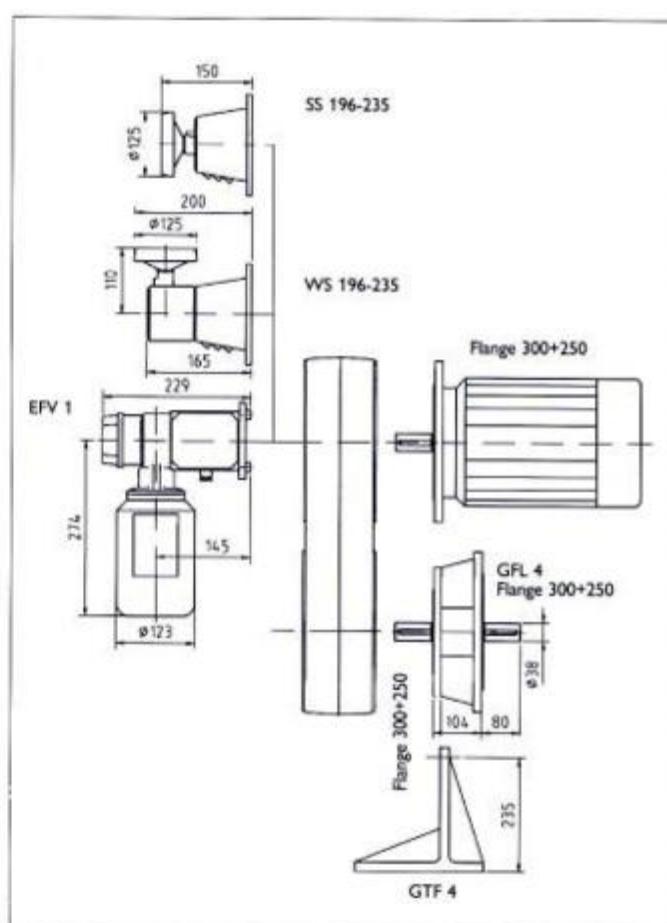
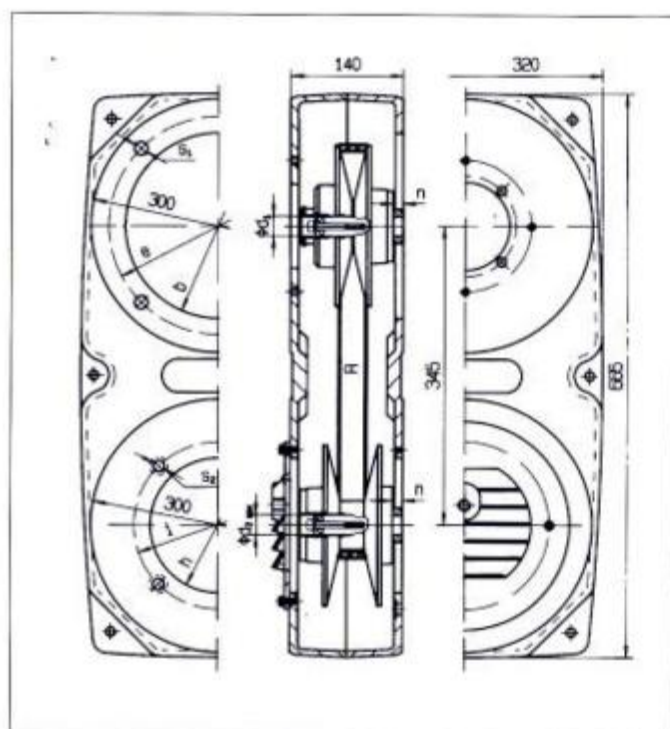

## RGAE 4

Motor size Type	Power [kW]	Nominal speed [rpm]	RGAE Type	Output power (max./min.) [kW]	Output speed (max./min.) [rpm]	Belt [Lw]	Speed range	Weight [N]
112 B5	4,0	1430	RGAE 4-235	3,6/1,6	4610/439	37 x 10 x 1180	1:10,5	220
132 B5	7,5	1450	RGAE 4-210	6,7/1,85	3970/530	37 x 10 x 1167	1:7,5	215

Motor 132 B14 B can also be mounted.

## Assembly dimensions in mm

RGAE-Typ	d <sub>1</sub>	e	b	s <sub>1</sub>	d <sub>2max.</sub>	l	h	s <sub>2</sub>	n
RGAE 4-235	28	215	183	13	28	265 215	233 183	13 13	9
RGAE 4-210	38	265	233	13	38	265 215	233 183	13 13	9



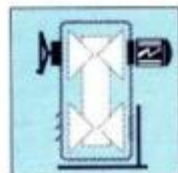
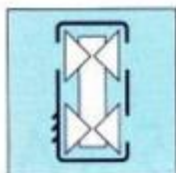

## Assembly units

# RGAE 5

$$P_{1 \max.} = 15,0 \text{ kW}$$

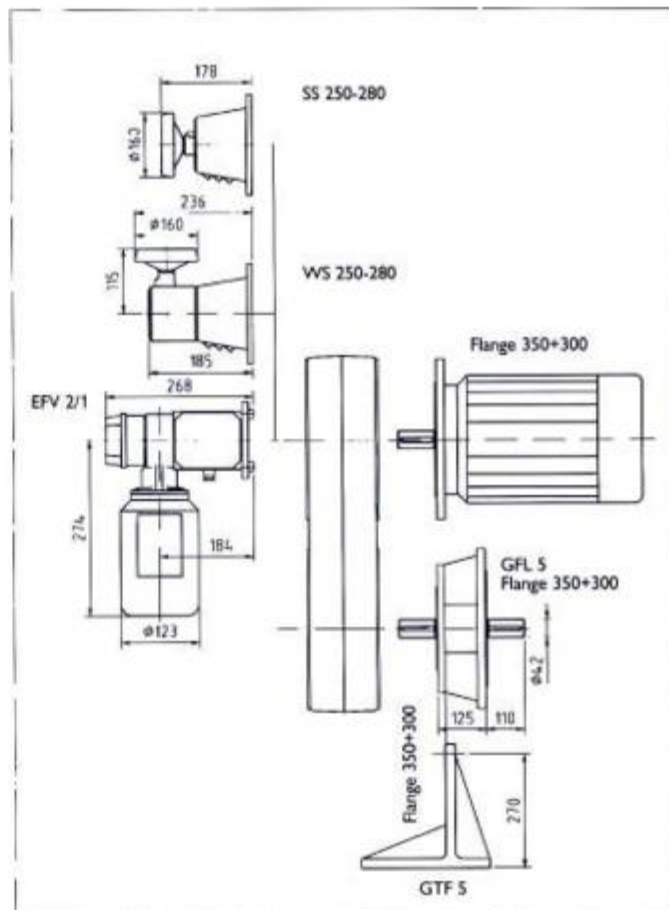
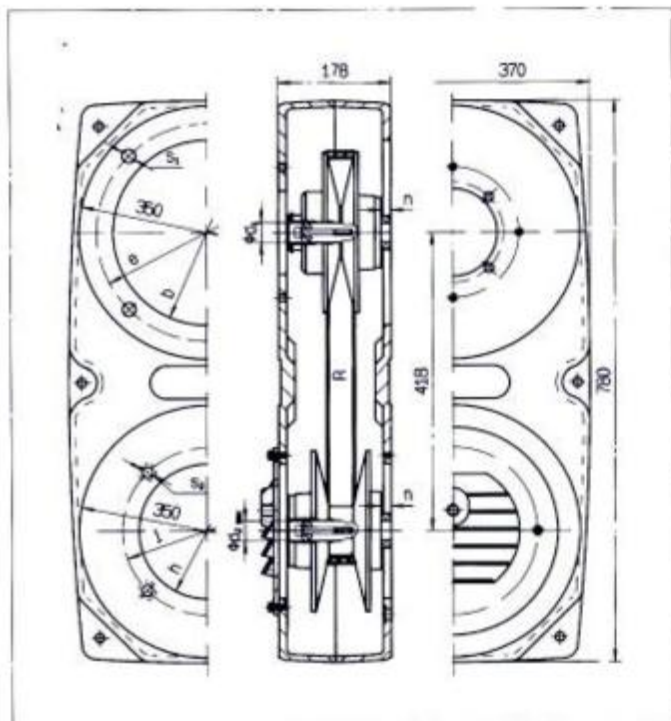

## RGAE 5

Motor size Type	Power [kW]	Nominal speed [rpm]	RGAE Type	Output power (max./min.) [kW]	Output speed (max./min.) [rpm]	Belt [Lw]	Speed range	Weight [N]
160 B5	11	1450	RGAE 5-250	9,9/2,7	3970/530	47 x 12 x 1383	1:7,5	380
160 B5	15	1455	RGAE 5-280	13,5/4,1	4240/500	55 x 15 x 1475	1:8,5	450

## Assembly dimensions in mm

RGAE-Typ	d <sub>1</sub>	e	b	s <sub>1</sub>	d <sub>2max.</sub>	i	h	s <sub>2</sub>	n
RGAE 5-250	42	300	253	17	42	300 265	253 233	17 13	16,5
RGAE 5-280	42	300	253	17	42	300 265	253 233	17 13	8





## Assembly units

# RGAE 6

$$P_{1 \max.} = 30,0 \text{ kW}$$

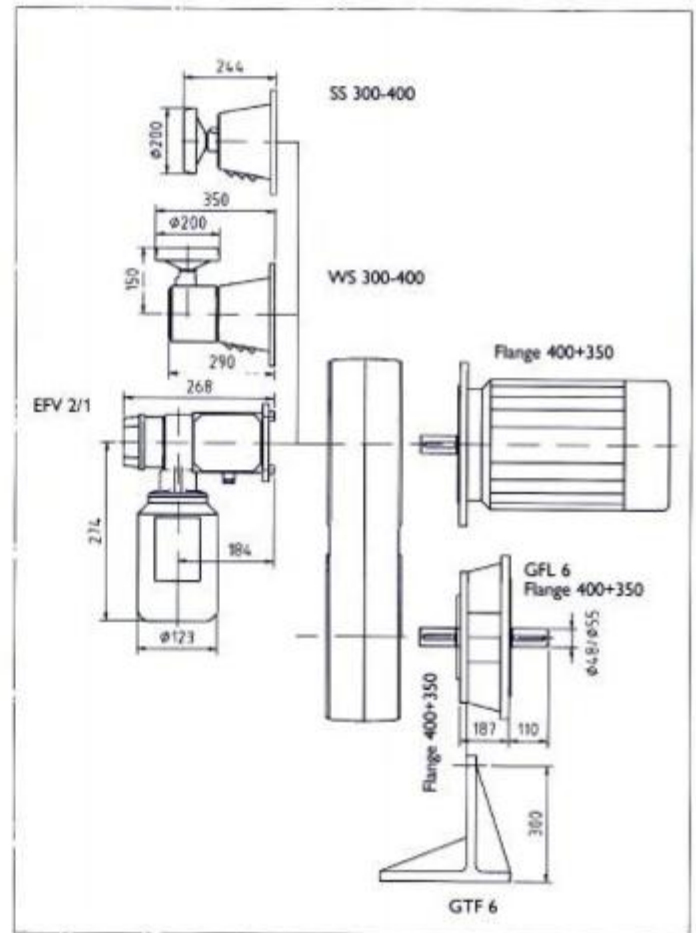
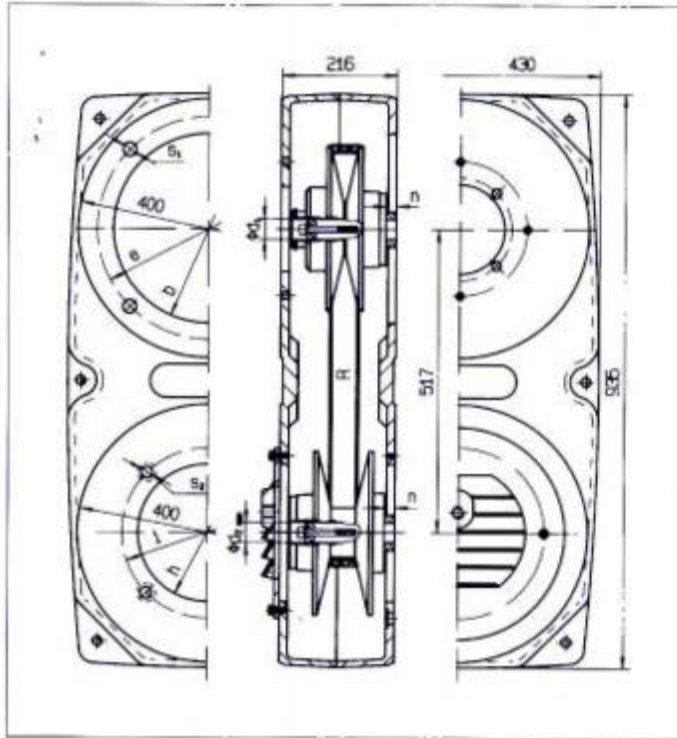

## RGAE 6

Motor size Type	Power [kW]	Nominal speed [rpm]	RGAE Type	Output power (max./min.) [kW]	Output speed (max./min.) [rpm]	Belt [Lw]	Speed range	Weight [N]
180 B5	18,5	1460	RGAE 6-300	16,6/6,1	3920/545	51 x 16 x 1695	1:7,2	700
180 B5	22	1460	RGAE 6-300	19,8/6,1	3920/545	51 x 16 x 1695	1:7,2	700
200 B5	30	1465	RGAE 6-350	27/10	4000/540	70 x 18 x 1778	1:7,4	750

## Assembly dimensions in mm

RGAE-Type	d <sub>1</sub>	e	b	s <sub>1</sub>	d <sub>2max.</sub>	i	h	s <sub>2</sub>	n
RGAE 6-300	48	300	253	17	48	350 300	303 253	17	15,5
RGAE 6-350	55	350	303	17	55	350 300	303 253	17	11

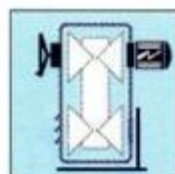
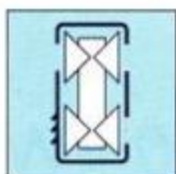

## Assembly units

# RGAE 7

$$P_{1 \max.} = 55,0 \text{ kW}$$

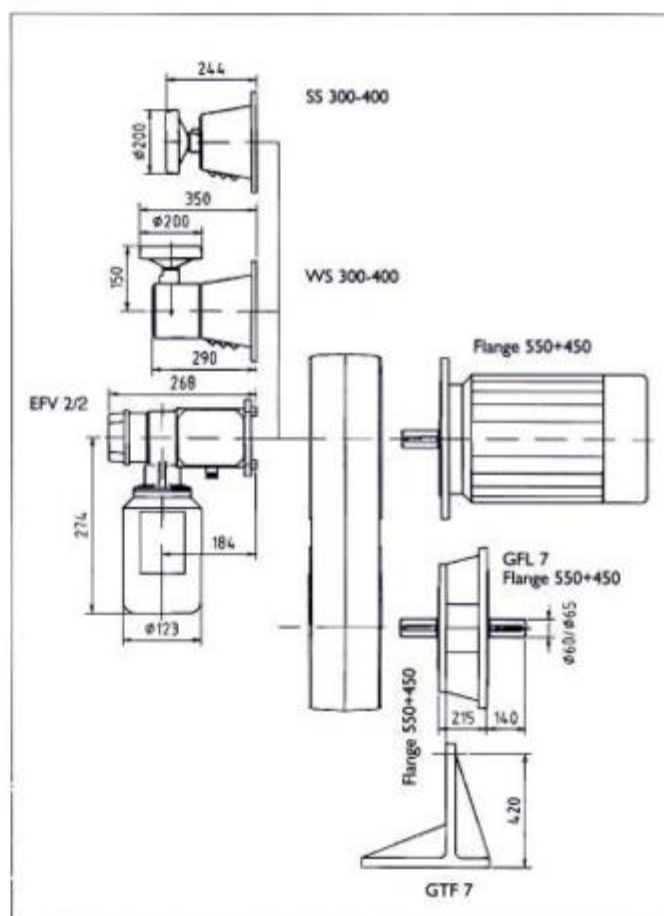
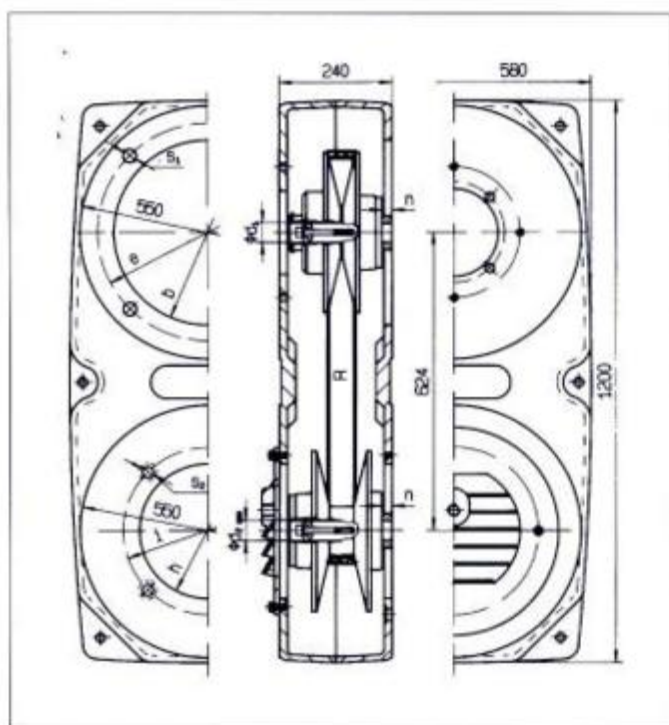

## RGAE 7

Motor size Type	Power [kW]	Nominal speed [rpm]	RGAE Type	Output power (max./min.) [kW]	Output speed (max./min.) [rpm]	Belt [Lw]	Speed range	Weight [N]
225 B5	37	1475	RGAE 7-375	33,3/16,0	2760/520	83 x 23 x 2066	1:5,3	~ 0,9
225 B5	45	1475	RGAE 7-375	40,5/16,0	2760/520	83 x 23 x 2066	1:5,3	~ 0,9
250 B5	55	1475	RGAE 7-400	49,5/16,8	2575/515	83 x 23 x 2145	1:5,0	~ 1,0

## Assembly dimensions in mm

RGAE-Type	d <sub>1</sub>	e	b	s <sub>1</sub>	d <sub>2max.</sub>	i	h	s <sub>2</sub>	n
RGAE 7-375	60	400	353	17	60	500 400	453 353	17 17	10
RGAE 7-400	65	500	453	17	65	500 400	453 353	17 17	10



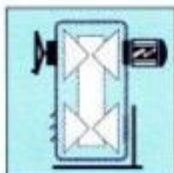
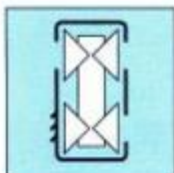

## Assembly units

# RGAE 8 + 9 $P_{1 \max.} = 160,0 \text{ kW}$

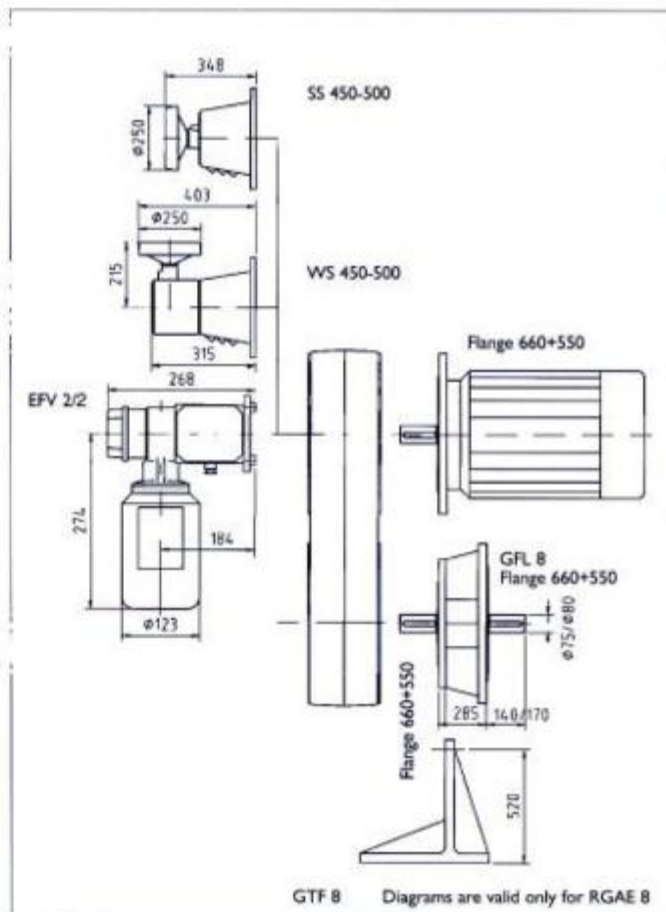
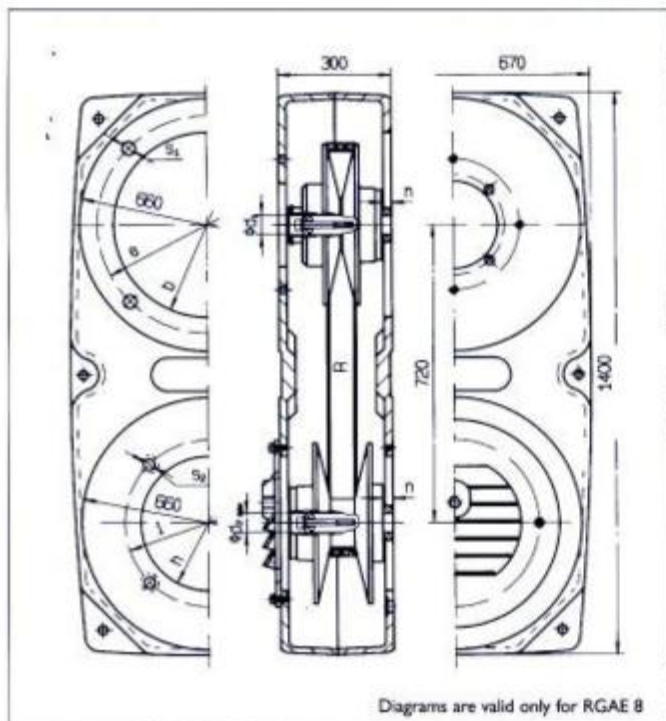

## RGAE 8 + RGAE 9

Motor size Type	Power [kW]	Nominal speed [rpm]	RGAE Type	Output power (max./min.) [kW]	Output speed (max./min.) [rpm]	Belt [Lw]	Speed range	Weight [N]
280 B5	75	1480	RGAE 8-450	67,5/21,2	2770/630	83 x 26 x 2488	1:4,4	~ 2,3
280 B5	90	1480	RGAE 8-500	81,0/36,5	1992/498	83 x 26 x 2675	1:4,0	~ 2,5
315 B5	110	1480	RGAE 8-500	99,0/36,5	1992/498	83 x 26 x 2675	1:4,0	~ 2,5
315 B5	132	1480	RGAE 9-600	119/75	1965/655	*	1:3,0	*
315 B5	160	1480	RGAE 9-600	145/75	1965/655	*	1:3,0	*

## Assembly dimensions in mm

RGAE-Type	d <sub>1</sub>	e	b	s <sub>1</sub>	d <sub>2max.</sub>	i	h	s <sub>2</sub>	n
RGAE 8-450	75	500	453	17	80	600	553	21	10
RGAE 8-500/90	75	500	453	17	80	500	453	17	10
RGAE 8-500/110	80	600	553	21	80	600	553	21	10
RGAE 9-600/132	80	*	*	*	90	*	*	*	*
RGAE 9-600/160	80	*	*	*	90	*	*	*	*

\* Please enquire

