

DYSTRYBUTOR

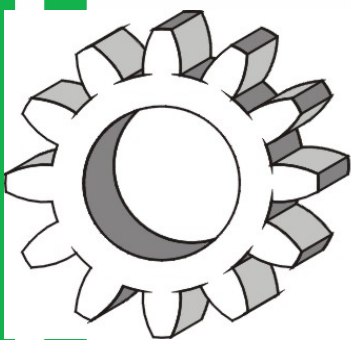

TECHNICAL

GRZEGORZ TĘGOS

TECHNIKA NAPĘDU I TRANSMISJI MOCY

62-600 Koło, ul. Toruńska 212
tel. 0-63/ 27 25 478 / fax. 0-63/ 26 16 258

www.technical.pl
biuro@technical.pl

Sklep internetowy
www.sklep.technical.pl

Taper Lock:
Calowy i Metryczny
Tuleje zbieżne



Antriebselemente

SIT Taper bushing SER-SIT®

Description

SER-SIT® taper lock bush is designed to give the following:

- perfect assembly
- rapid dismounting of the pulley and other transmission equipment
- no special tools requirement except hexagonal key.

The large range of available finished bores ensures that an immediate assembly can be made thus avoiding costly factory downtime. Fastening by SER-SIT® bushes allows the removal of any clearance between hub and bore so that fretting corrosion is positively eliminated. SER-SIT® bushes are interchangeable with all similar types sold throughout the world.



Keyway

UNI 6604-69 / DIN 6885		
Diameter of the bore [mm]	b [mm]	t ₂ [mm]
9 ÷ 10	3	1,4
11 ÷ 12	4	1,8
13 ÷ 17	5	2,3
18 ÷ 22	6	2,8
23 ÷ 30	8	3,3
31 ÷ 38	10	3,3
39 ÷ 44	12	3,3
45 ÷ 50	14	3,8
51 ÷ 58	16	4,3
59 ÷ 65	18	4,4
66 ÷ 75	20	4,9
76 ÷ 85	22	5,4
86 ÷ 95	25	5,4
96 ÷ 110	28	6,4
111 ÷ 130	32	7,4

Diameter of the bore [inch]	b [inch]	t ₂ [inch]
3/8 - 1/2	1/8	1/16
9/16 - 3/4	3/16	3/32
13/16 - 1	1/4	1/8
1-1/16 - 1-1/4	5/16	1/8
1-5/16	3/8	1/8
1-5/8 - 1-3/4	7/16	5/32
1-7/8 - 2	1/2	5/32
2-1/8 - 2-1/2	5/8	7/32
2-5/8 - 3	3/4	1/4
3-1/8 - 3-1/2	7/8	5/16
3-3/4 - 4	1	3/8
4-1/4 ÷ 5	1-1/4	7/16

Reduced keyway to be considered only for cases shown in the below table.

Diameter of the bore [mm]	Taper Bushing SER-SIT® type	b [mm]	t ₂ [mm]
24 - 25	1008	8	1,3
28	1108	8	1,3
35	1310	10	1,3
42	1615	12	2,2
65	2517	18	3,3
Diameter of the bore [inch]	Taper Bushing SER-SIT® type	b [inch]	t ₂ [inch]
1	1008	1/4	1/16
1-1/8	1108	5/16	5/64
1-5/8 - 1-3/4	1615	7/16	1/8
3-1/2	3535	7/8	1/4
3-3/4 - 4	4040	1	1/4

Tuleje zbieżne Taper Lock to tuleje stożkowe zaciskowe które dzięki swojej konstrukcji zapewniają:

- *łatwy i doskonały montaż
- *szybki demontaż koła pasowego czy innego elementu przeniesienia napędu
- *nie wymagają specjalnych narzędzi z wyjątkiem klucza sześciokątnego imbusowego

Tuleje zbieżne Taper Lock posiadają duży wybór gotowych otworów co zapewnia natychmiastowy montaż, co również pozwala uniknąć kosztownych przestoju w fabryce. Mocowanie za pomocą tulei zaciskowych Taper Lock pozwala na usunięcie wszelkich luzów pomiędzy otworem a wałkiem, co skutecznie eliminuje korozję cierną. Tuleje zaciskowe SER-SIT są wymienne ze wszystkimi podobnymi tulejami zaciskowymi sprzedawanymi na całym świecie

Technical features of taper bushings SER-SIT®

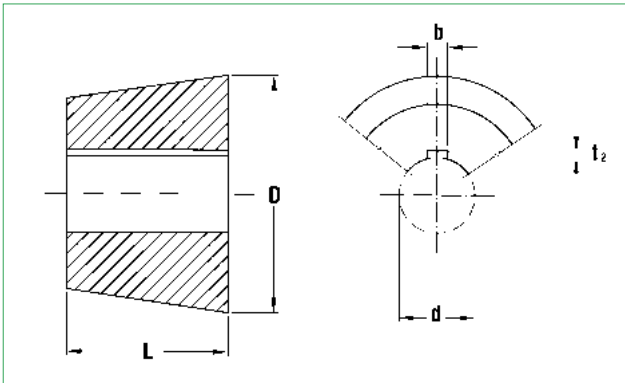

Part Number **BC 4025 F20**

Taper bushing SER-SIT®

Size

Bore diameter [mm]

Taper Bushing SER-SIT® size	Diameter of the bore d		L [mm]	D [mm]	screws				M _S [Nm]
	mm	inches			N°	Withworth	Length [mm]	Key [mm]	
1008 (25.20)	mm	11 12 14 15 16 18 19 20 22 24* 25*	22,3	35	2	1/4	13	3	5,5
	inches	3/8 1/2 5/8 3/4 7/8 1*							
1108 (28.20)	mm	11 12 14 15 16 17 18 19 20 22 24 25 26 27 28*	22,3	38	2	1/4	13	3	5,5
	inches	3/8 1/2 5/8 3/4 7/8 1 1 1/8*							
1210 (30.25)	mm	11 12 14 15 16 18 19 20 22 24 25 26 28 30 32	25,4	47	2	3/8	16	5	20
	inches	1/2 5/8 3/4 7/8 1 1 1/8 1 1/4							
1215 (30.40)	mm	12 14 15 16 18 19 20 22 24 25 26 28 30 32	38,1	47	2	3/8	16	5	20
	inches	1/2 5/8 3/4 7/8 1 1 1/8 1 1/4							
1310 (35.25)	mm	14 16 18 19 20 22 24 25 28 30 32 35*	25,4	52	2	3/8	16	5	20
	inches	1/2 5/8 3/4 7/8 1 1 1/8 1 1/4 1 3/8							
1610 (40.25)	mm	12 14 15 16 18 19 20 22 24 25 26 28 30 32 35 38 40 42	25,4	57	2	3/8	16	5	20
	inches	3/8 1/2 5/8 3/4 7/8 1 1 1/8 1 1/4 1 3/8 1 1/2 1 5/8							
1615 (40.40)	mm	12 14 15 16 18 19 20 22 24 25 26 28 30 32 35 38 40 42*	38,1	57	2	3/8	16	5	20
	inches	1/2 5/8 3/4 7/8 1 1 1/8 1 1/4 1 3/8 1 1/2 1 5/8* 1 3/4*							
2012 (50.30)	mm	14 15 16 18 19 20 22 24 25 26 28 30 32 35 38 40 42 45 48 50	31,8	70	2	7/16	22	5	30
	inches	5/8 3/4 7/8 1 1 1/8 1 1/4 1 3/8 1 1/2 1 5/8 1 3/4 1 7/8 2							
2517 (65.45)	mm	18 19 20 22 24 25 28 30 32 35 38 40 42 45 48 50 55 60 65*	44,5	85	2	1/2	25	6	50
	inches	3/4 7/8 1 1 1/8 1 1/4 1 3/8 1 1/2 1 5/8 1 3/4 1 7/8 2 2 1/8 2 1/4 2 3/8 2 1/2							
3020 (75.50)	mm	22 25 28 30 32 35 38 40 42 45 48 50 55 57 60 65 70 75	50,8	108	2	5/8	32	8	90
	inches	1 1/4 1 3/8 1 1/2 1 5/8 1 3/4 1 7/8 2 2 1/8 2 1/4 2 3/8 2 1/2 2 5/8 2 3/4 2 7/8 3							
3030 (75.75)	mm	25 28 30 32 35 38 40 42 45 47 48 50 55 60 65 70 75	76,2	108	2	5/8	32	8	90
	inches	1 1/4 1 3/8 1 1/2 1 5/8 1 3/4 1 7/8 2 2 1/8 2 1/4 2 3/8 2 1/2 2 5/8 2 3/4 2 7/8 3							
3535 (90.90)	mm	25 35 38 40 42 45 48 50 55 60 65 70 75 80 85 90	88,9	127	3	1/2	38	10	115
	inches	1 1/2 1 5/8 1 3/4 1 7/8 2 2 1/8 2 1/4 2 3/8 2 1/2 2 5/8 2 3/4 2 7/8 3 3 1/8 3 1/4 3 3/8 3 1/2*							
4040 (100.100)	mm	40 42 45 50 55 60 65 70 75 80 85 90 95 100	101,6	146	3	5/8	44	14	170
	inches	1 3/4 2 2 3/4 3 1/2 3 3/4* 4*							
4545 (115.115)	mm	55 60 65 70 75 80 85 90 95 100 105 110	114,3	162	3	3/4	51	14	195
	inches	3 3 1/2 4							
5050 (125.125)	mm	50 60 65 70 75 80 85 90 95 100 110 115 120 125	127,0	178	3	7/8	57	17	275
	inches	3 1/2 4							
6050** (150.125)	mm	80-85-90-95-100-105-110-115-120-125-130-135-140-145-150	127,0	235	3	1-1/4	107	48	650
	inches								

Taper bushing having bore diameters in **bold** type are made in steel instead of cast iron

M_S = screw tightening torque
 * = reduced keyway
 ** = hexagonal head screw

Assembly and disassembling of SER-SIT® conical bushing

- Before fitting the bushing into the pulley, carefully clean the bore and the conical parts.
- Fit the bushing into the pulley taking care that the threaded half holes of the pulley are in coincidence of the unthreaded holes of the bushing.
- Hand tighten the screws.
- Fit the pulley to the shaft after having carefully cleaned it. Position it and tighten the screws alternately.

- Disassembly: remove screws and put a new one in the jacking hole tightening it until the hub is released.

Note

Ensure that the top of the keyway doesn't get in contact with the bottom of the seat. It is recommended to keep a certain clearance.

In applications characterized by strong vibrations, we strongly recommend checking the tightening of the set screws after a few hours of operation under load and, subsequently, at regular time intervals. SIT Spa cannot be held responsible for any consequences deriving from accidental unscrewing of the set screws during use.

SER-SIT® conical bushing: slip torques and allowable axial load

The slip torques have been calculated considering the nominal tightening torque for the screws (Ms), a friction coefficient value $\eta = 0,14$ and in case of assembly without keyway.

Taper Bushing SER-SIT®	Bore diameter d [mm]	Slip torque [Nm]	Allowable axial load [N]
1008	12	29	3990
	19	51	4940
	24	66	5490
1108	12	28	-
	19	49	4630
	24	64	5220
	28	79	5720
1210 + 1215	16	82	8840
	19	105	9800
	24	142	10900
	32	210	12300
1610 + 1615	19	98	-
	24	135	9570
	38	240	11900
	42	265	12700
2012	24	165	11500
	38	310	14400
	42	340	15700
	48	400	-
	50	420	16700
2517	24	220	-
	38	380	17000
	42	430	18500
	48	510	-
	55	600	21000
	60	670	22300
3020 + 3030	38	520	23900
	48	730	26100
	55	890	29900
	60	970	31500
	75	1300	34500
3535	42	1000	41000
	60	1580	49800
	75	2150	54800
	90	2600	59000
4040	48	1700	-
	60	2300	70200
	75	3150	77200
	100	4400	89400
4545	55	2500	79600
	75	3900	93000
	100	5500	107700
	110	6300	-
5050	75	3950	91800
	100	5650	106600
	125	7370	119500

TAPER BUSHING

FgVSe fa] ai SE7DŽE F S_ a_ Wfk ¶l Yai W Vabge US^ VāTU W[Vāeai W
? a_ Wfk ba ¶l Yg laeSkaT¶U a` W gi lY^ V [W[W ` a_ [S^ Wa_ a_ Wfg Va] d UW[S dgT/? efi
[i dō-Uk ` [] S fS dS ` / "l#&adl i bd kbSV] g_ a` fs g fg VMSU[e] ai WTWi bgefg